

## To Meet The Diverse Needs

- Carrier
- Commercial lawn mower
- Engine driven sprayer
- Multifunctional machinery
- Orchard sprayer
- Reaper equipment
- Rice transplanter
- Transplanting equipment .....
- Generator
- Log splitter
- Pressure washer
- Shredder
- Snow thrower
- Water pump .....
- Concrete vibrating rod
- Gasoline engine welder
- Power trowel
- Plate compactor
- Road cutter
- Spray paint equipment .....
- Engine driven bolt wrench
- Hydraulic tamping equipment
- Hydraulic lift equipment
- Hydraulic railway track-laying Machine
- Internal combustion switch grinding equipment .....

## Optional Configurations

- A variety of output shafts
- Electric starter (GT1000 and GT1300)
- Dual element air cleaner (GT600 and GT1300)
- Oil bath air cleaner (GT600, GT1000 and GT1300)
- Low oil alert
- Resin fuel tank (GT241, GT400 and GT600)
- Tail pipe (adjustable direction)
- Spark arrester available
- Different direction recoil starter extended length rope available
- Remote control mode
- Spark plug cap (meet EMC requirement)
- AC power generation coil
- 1/2 speed reduction

Brilliant Group Industry Inc.

159 N. Central Ave., Valley Stream, NY 11580, USA  
Tel: +1-516-218-2810 Fax: +1-516-706-3262

9123 Santa Anita Ave., Rancho Cucamonga, CA 91730, USA  
Tel: +1-909-581-1212 Fax: +1-909-581-1215  
www.brilliantindustry.com  
E-mail: info@brilliantindustry.com  
US telephone toll-free No.: 888-666-0292

Shanghai Brilliant Trading & Development Co., Ltd.  
Floor 33, 257 Siping Road, Shanghai 200081, China  
Tel: +86-21-6521 2718, Fax: +86-21-6521 4386  
E-mail: engine@brilliantglobe.cn

Manufacture: Shanghai Xingbo Industrial Co., Ltd.  
67 Caoli Road, Fengjing Town, Shanghai 201502, China  
Tel: +86-21-5736 4891, Fax: +86-21-5736 1738  
www.brilliantengines.com  
E-mail: engine@brilliantglobe.cn

**BRILLIANT**  
ENGINES

# BRILLIANT

## EXCELLENT OHV ENGINE



ALL MITSUBISHI GT SERIES ENGINES' TECHNOLOGIES AND PATENTS HAVE BEEN COPYRIGHT PROTECTED AND OWNED ONLY BY BRILLIANT BASED ON THE AGREEMENT(S)

1708GT



## OHV Air Cooled Gasoline Engine

### GT Series

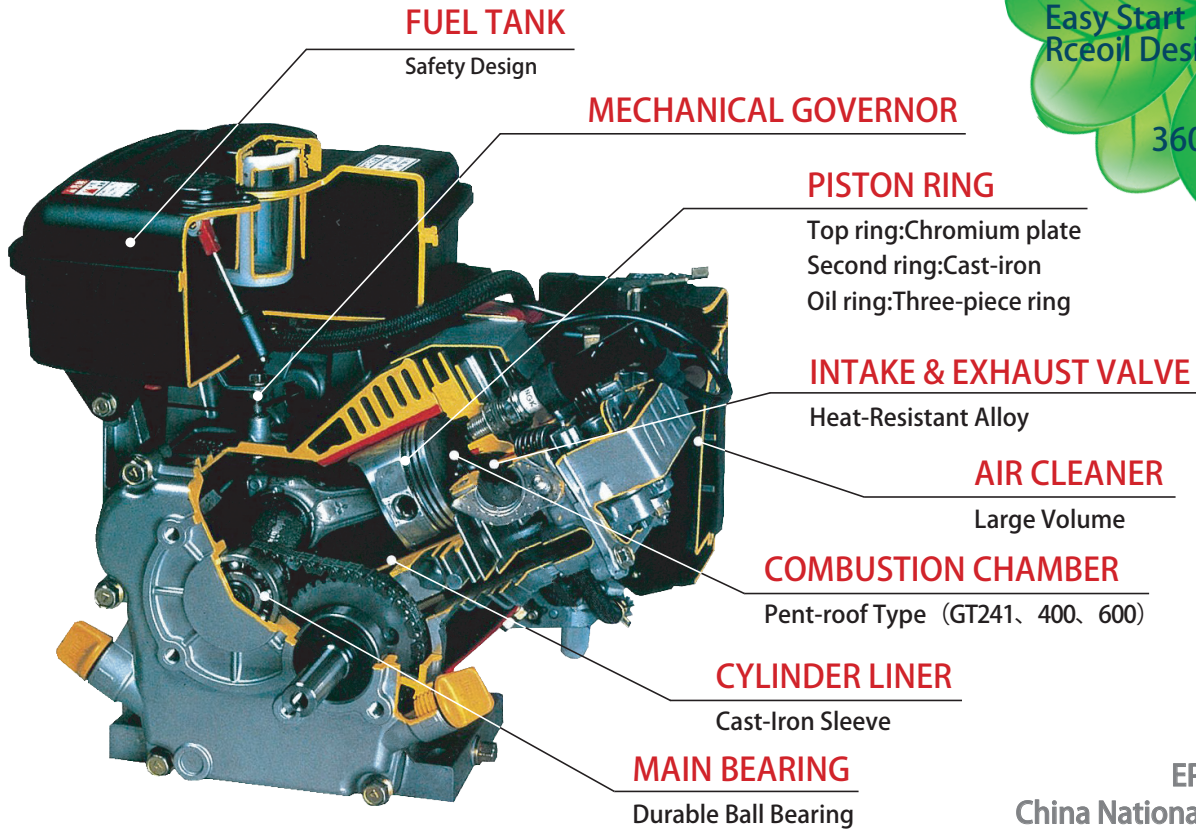
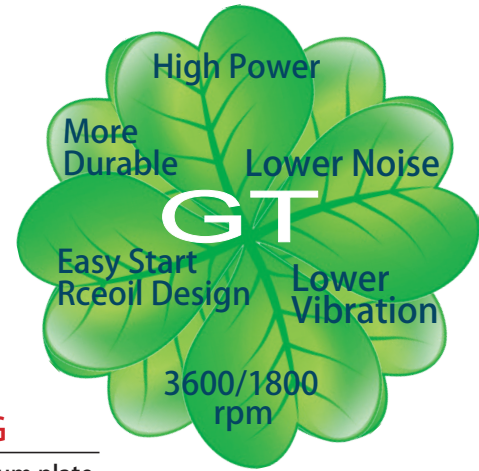

CE & EU Stage II  
EPA Phase 3 & CARB  
China National Emission Stage II  
Certified

## A New Standard In OHV Performance

The quality of engine has been established by satisfying the various needs of each customer in Japan and worldwide constantly. With 60 years of practice, development and integrated experience, our engine has been matured to near perfection as the world's leading general engine.

The current fully developed combustion technologies are polished to employ the pent-roof type combustion chamber to replace the traditional bathtub type combustion chamber. As a result, a smooth air flow with reduced bent loss is achieved in the intake / exhaust

passages. The spark plug near the center of the combustion chamber helps to increase output by up to 10%.

In the laboratory, our engines achieved the commercial standard of durability at full load testing. With approved rigorous outdoor exposure test, rapid response and well performed applications on both low temperature and high temperature environment, our new series of engines actually succeeded in achieving the "GT Series" highest quality level standard.

### ● The features of new OHV GT series

Clean and powerful engine with ideal shape of combustion chamber  
"PENT-ROOF TYPE"  
combustion chamber (In addition to GT1000/GT1300)

- Smooth Air Flow
- Centered Spark Plug

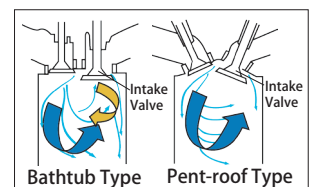
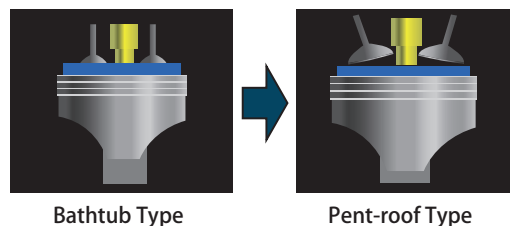

### THE UNIQUE DESIGN OF 'PENT-ROOF TYPE' COMBUSTION CHAMBER

# Performance Puts OHV GT Series A Step Ahead

## Product Features

### High Surge Power with Excellent Speed Adjustment

Optimizing Camshaft outline and decreasing the rubbing of parts, etc., increase the Max. output power, promote performance development space.

The unique speed governing control system produces a completely developed power performance, while increasing the engine stability on both idling and full speed rotation stage.

### High Durability

The crankshaft, intake and exhaust valves, and other main components have been reinforced along with enlarged ball bearings. The governor shaft, throttle shaft and choke shaft have been dust-proofed to minimize unnecessary wear and tear. Extended duration of endurance test can be performed as needed with our improved design.

### Lower Noise, Lower Vibration

Increasing the inflexibility of the cylinder block and improving the shape of cooling fan, make wind noise minimized, the latest designed cam contour reduces the noise of valve transmission to control mechanical motion noise substantially. Research the material and shape of the reciprocating movement part carefully, decrease the part weight which reduce the vibromotive force and optimize equilibrium rate of the crankshaft to control the engine's vibration furthest.

### Easy Start Recoil Design

Improved mechanical de-compression mechanism system, through more stringent management to achieve greater consistency, allowing you to experience the easier recoil starting pulling. Compared to the traditional engine, the force of recoil reduced over 15% on tension, which is defined as starting at easiest possible.

The GT series engines, equipped with the industry's highest standard of carburetor anti-corrosion treatment, inhibited corrosion of long-term fuel placement, improved starting performance.

## GT 1/2 Speed Reduction Engine

### Optional models

GT400 L Type



GT600 L Type



GT1000 L Type



GT1300 L Type

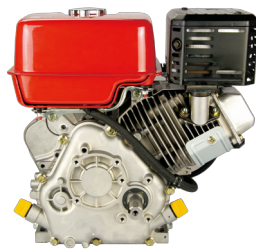

### The smallest size, The maximized torque

GT400, GT600, GT1000 (except for GT1300) adopted internal speed reduction technology, achieved the smallest size, maximized torque among the same category engines, the best installation mount size, and minimized power loss. Guaranteed the stability of applications during operation.



GT Speed reduction engine series



Other products

### The optimized fuel economy

Compared with products of other brands, the fuel consumption is decreased by 15%~20%, through the stable power output, ensure optimized running and fuel economy.

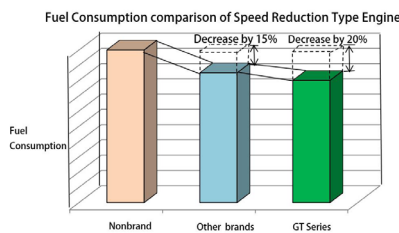

### Long-life

Adopting forged camshaft and crankshaft, oblique tooth gear transmission, decrease transmission noise, ensure longest operation running time.



## Industrial Plant Facility



## Global Group Corporation



## Professionalized quality management



- A multinational corporation group with over 20 years history.
- A commercial grade general-purpose gasoline engine brand originated from United States.
- All Mitsubishi GT series engines' technologies and patents have been copyright protected and owned only by Brilliant based on the agreement(s).





# GT400

**4.0**

GROSS HP  
5.0 gross kW  
1.677cc

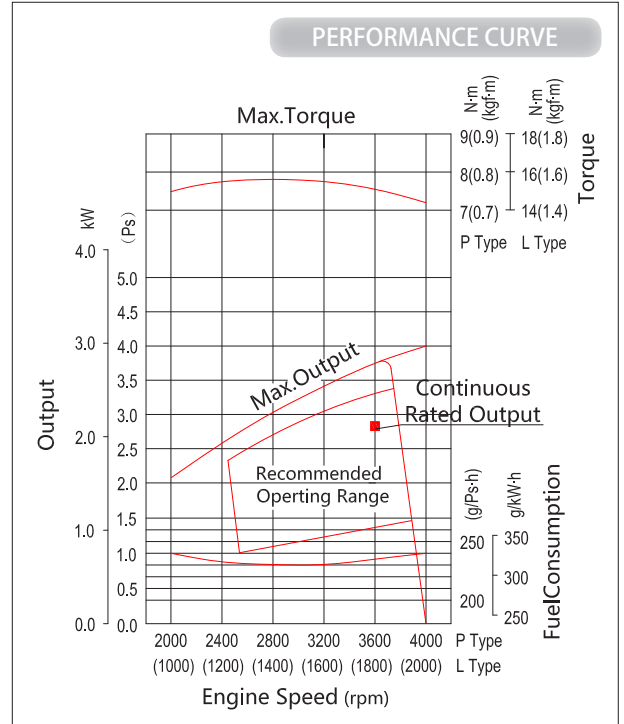

Displacement	126.8cc
Rated output	P type: 2.1kW/3600rpm (2.8PS/3600rpm) L type: 2.1kW/1800rpm (2.8PS/1800rpm)
Max. output	2.9kW/4000rpm (4.0PS/4000rpm)
Max. torque	P type: 7.65/2800N · m/rpm 0.78/2800kgf · m/rpm L type: 15.3/1400N · m/rpm 1.56/1400kgf · m/rpm
Fuel tank capacity	2.5L
Dry weight	P type: 12.7kg L type: 13.7kg
Outline dimension	L: 297.5mm × W: 340mm × H: 315mm



P type: Standard Crankshaft Output



L type: Internal 1/2 Speed Reduction, Camshaft Output

## P type

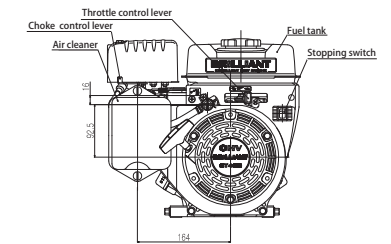
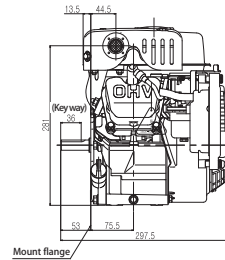
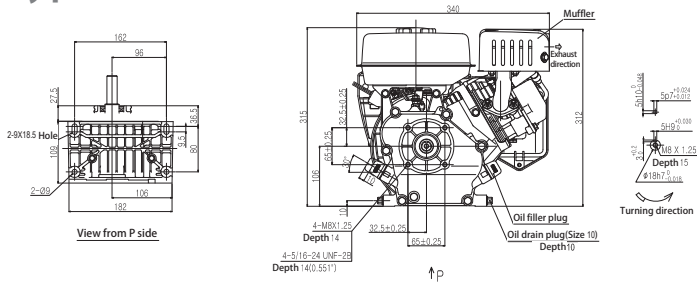

## L type

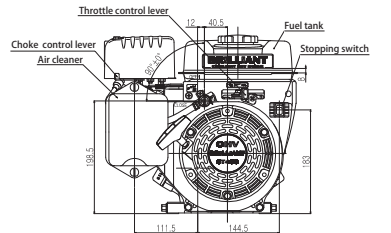
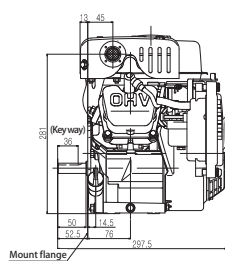
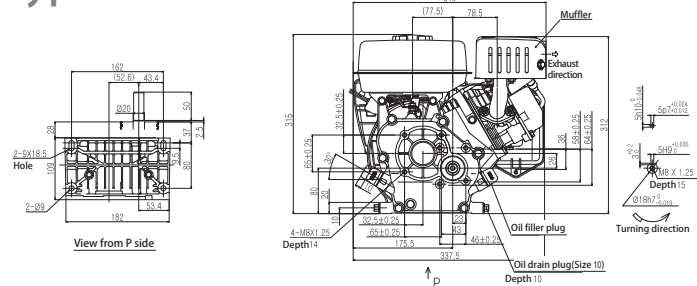

## GT600

**6.0**  
GROSS HP  
4.4 gross kW  
1.6BHP



 P type: Standard Crankshaft Output

 L type: Internal 1/2 Speed Reduction, Camshaft Output

### PERFORMANCE CURVE

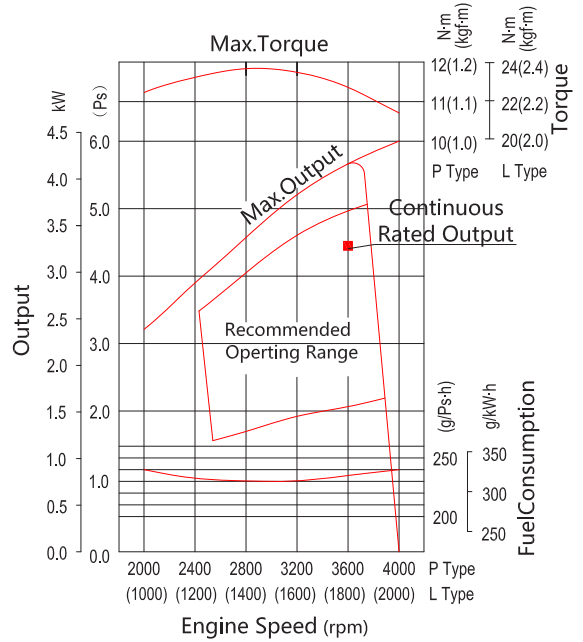

Displacement 181.6cc  
 Rated output P type: 3.3kW/3600rpm (4.5PS/3600rpm)  
 L type: 3.3kW/1800rpm (4.5PS/1800rpm)  
 Max. output 4.4kW/4000rpm (6.0PS/4000rpm)  
 Max. torque P type: 11.6/2800N · m/rpm  
 1.18/2800kgf · m/rpm  
 L type: 23.1/1400N · m/rpm  
 2.36/1400kgf · m/rpm  
 Fuel tank capacity 3.8L  
 Dry weight P type: 14.9kg  
 L type: 15.8kg  
 Outline dimension L: 309mm × W: 354mm × H: 348mm

### P type

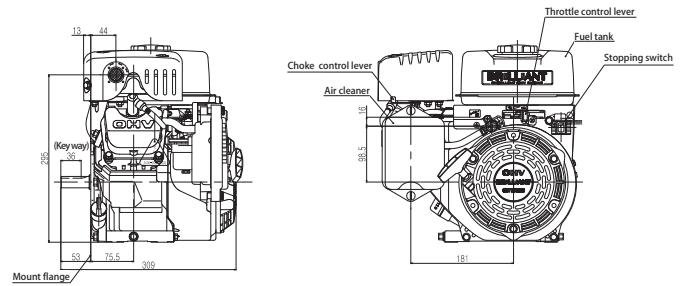
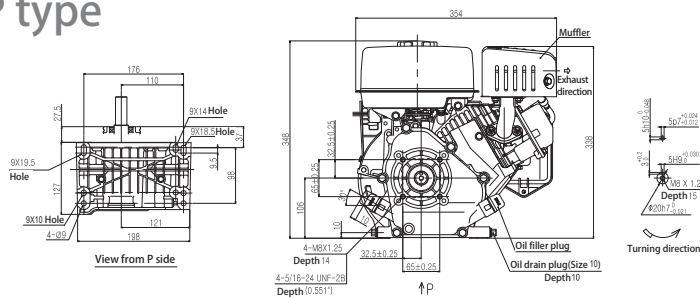

### L type

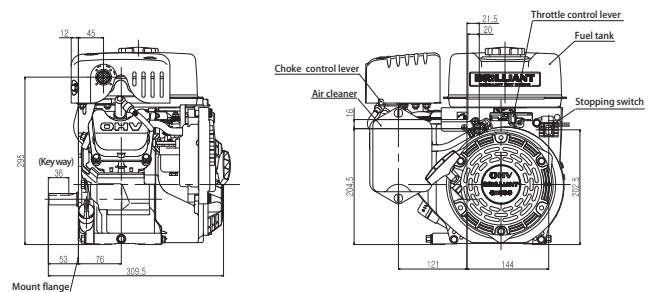
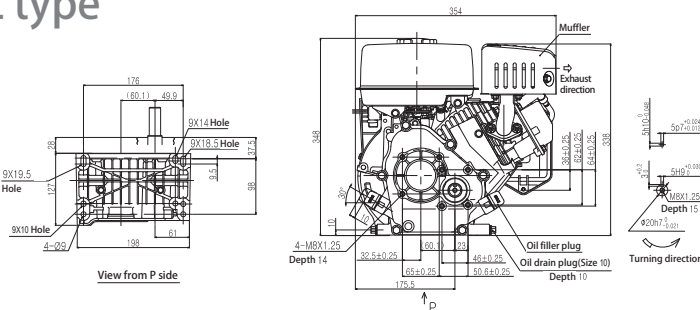



# GT1000

**10**  
GROSS HP  
7.5 gross kW  
1000cc



P type: Standard Crankshaft Output



L type: Internal 1/2 Speed Reduction, Camshaft Output

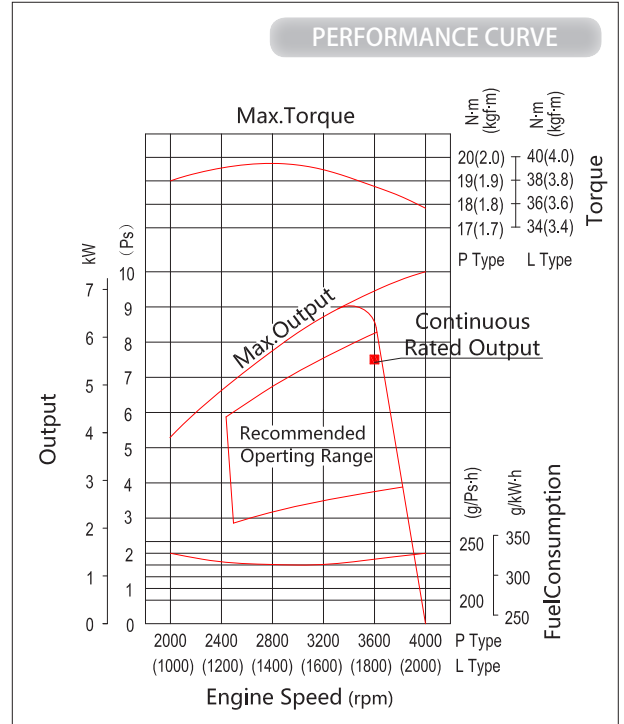

Displacement	296.6cc
Rated output	P type: 5.5kW/3600rpm (7.5PS/3600rpm) L type: 5.5kW/1800rpm (7.5PS/1800rpm)
Max. output	7.3kW/4000rpm (10.0PS/4000rpm)
Max. torque	P type: 19.3/2800N · m/rpm 1.97/2800kgf · m/rpm L type: 38.6/1400N · m/rpm 3.94/1400kgf · m/rpm
Fuel tank capacity	6.0L
Dry weight	P type: 27kg L type: 28kg
Outline dimension	L: 370mm × W: 434mm × H: 428mm

## P type

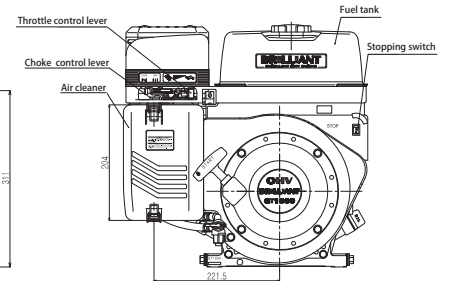
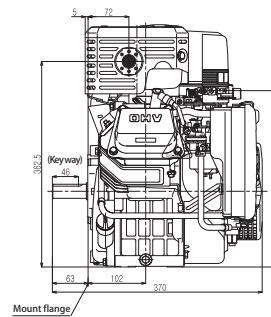
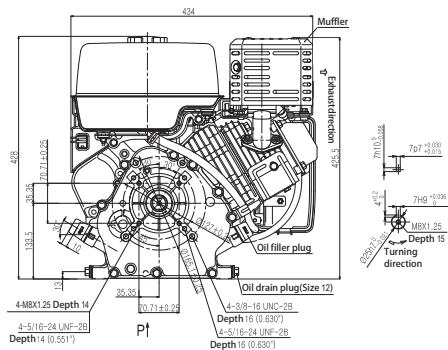
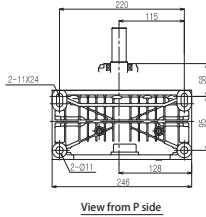

## L type

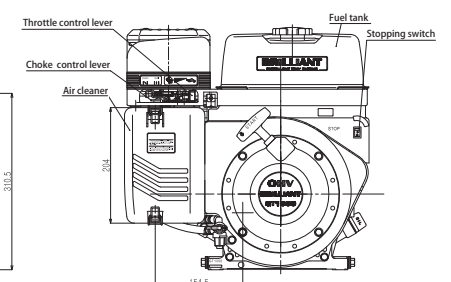
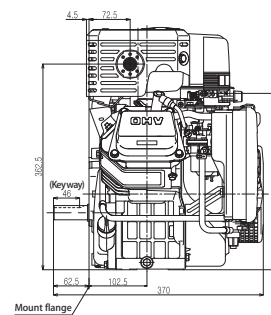
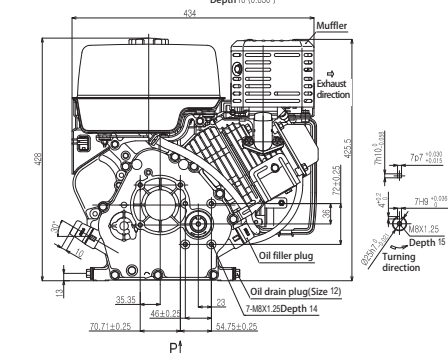
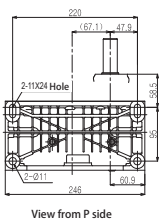

## GT1300

**13**  
GROSS HP  
8.8 gross kW  
3600

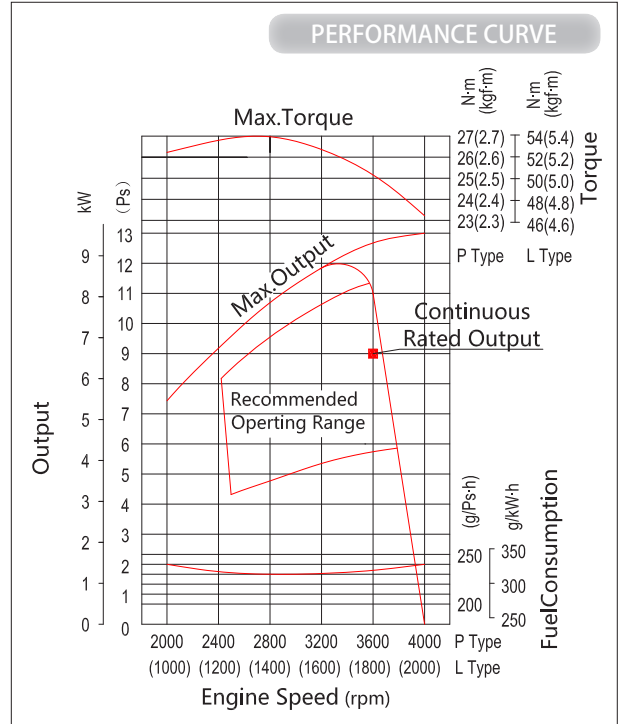

Displacement 391.9cc  
 Rated output P type: 6.6kW/3600rpm (9.0PS/3600rpm)  
 L type: 6.6kW/1800rpm (9.0PS/1800rpm)  
 Max. output 9.5kW/4000rpm (13.0PS/4000rpm)  
 Max. torque P type: 26.5/2800N · m/rpm  
 2.70/2800kgf · m/rpm  
 L type: 52.9/1400N · m/rpm  
 5.40/1400kgf · m/rpm

Fuel tank capacity 6.0L

Dry weight P type: 31kg  
 L type: 35kg

Outline dimension L: 409 (462.5) mm × W: 451 mm × H: 449mm

P type: Standard Crankshaft Output

L type: 1/2 Speed Reduction, Regular Shaft Output

### P type

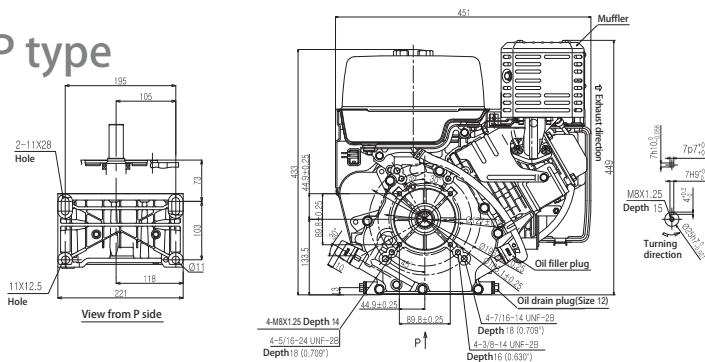

### L type

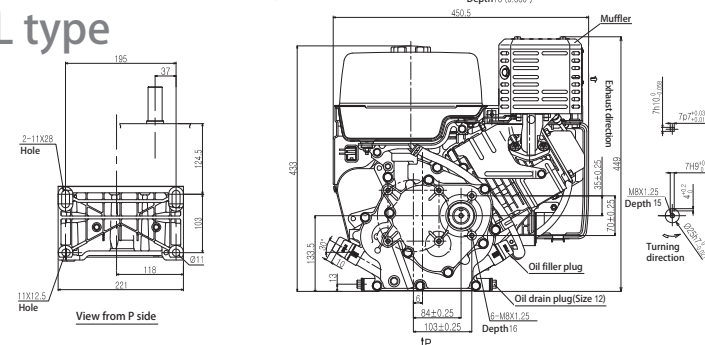



## Main specifications

Item		Model	GT241	GT400	GT600	GT1000	GT1300
Type		Air-cooled 4 stroke overhead valve gasoline engine with cylinder inclined by 30 degrees					
No. of cylinders-Bore × Stroke (mm)		1-51.6×38      1-62×42      1-68×50      1-80×59      1-89×63					
Displacement (cc)		79.6      126.8      181.6      296.6      391.9					
Continuous rated output	P type	kW/rpm (PS/rpm)	1.3/3600 (1.8/3600)	2.1/3600 (2.8/3600)	3.3/3600 (4.5/3600)	5.5/3600 (7.5/3600)	6.6/3600 (9.0/3600)
	L type	kW/rpm (PS/rpm)	—	2.1/1800 (2.8/1800)	3.3/1800 (4.5/1800)	5.5/1800 (7.5/1800)	6.6/1800 (9.0/1800)
Max. output		kW/rpm (PS/rpm)	1.8/4000 (2.4/4000)	2.9/4000 (4.0/4000)	4.4/4000 (6.0/4000)	7.3/4000 (10.0/4000)	9.5/4000 (13.0/4000)
Max. torque	P type	N.m/rpm (kgf.m/rpm)	4.31/3000 (0.44/3000)	7.65/2800 (0.78/2800)	11.6/2800 (1.18/2800)	19.3/2800 (1.97/2800)	26.5/2800 (2.70/2800)
	L type	N.m/rpm (kgf.m/rpm)	—	15.3/1400 (1.56/1400)	23.1/1400 (2.36/1400)	38.6/1400 (3.94/1400)	52.9/1400 (5.40/1400)
Engine rotation		Counter-Clockwise (facing PTO)					
Ignition system		Magneto ignition system					
Carburetor		Floating type butterfly valve, horizontal suction type					
Lubrication System		Splash lubrication system					
Lubricating oil		SE Class or higher, SAE#30 (#20 in winter)					
Lubricating oil volume (L)		0.4      0.6      0.6      1.0      1.0					
Air Cleaner		Foam Air Filter Element, Paper Air Filter Element, Oil bath type Air Filter Element					
Governor System		Centrifugal hammer method					
Fuel		Unleaded automobile gasoline					
Fuel tank capacity (L)		1.5      2.5      3.8      6.0      6.0					
Starting system		Recoil starter				Recoil starter or Electric starter	
Dry Weight (Kg)		9.5      12.7 (P type) / 13.7 (L type)      14.9 (P type) / 15.8 (L type)      27 (P type) / 28.5 (L type)      31 (P type) / 35 (L type)					

- The standard output torque is the value which is measured based on the standard assembly of the engine.
- The shown rotation speed is the rotation speed of output shaft.
- The changes of the engine specifications will not be noticed in advance.

### Product Presentation



Agriculture Machine Application Type



Farm Managing Machine Application Type



Construction Machine Application Type



Equipped for Garden and Municipal Administration Equipment

In addition to the above models, we can also develop some new models according to customer's requirements.

## GT241

JIS (KEYWAY)

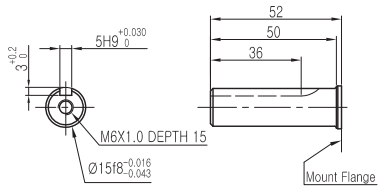

JIS (THREAD)

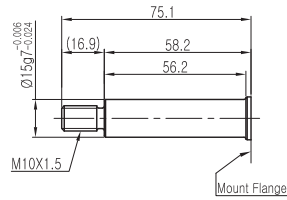

JIS (TAPER)

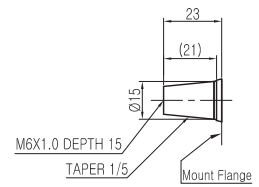

## GT400

JIS (KEYWAY)

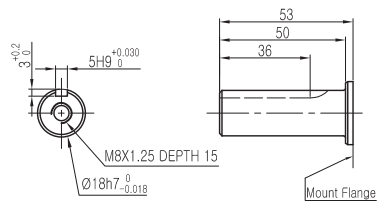

JIS (THREAD)

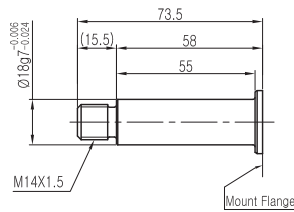

JIS (TAPER)

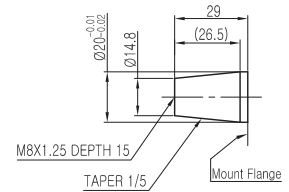

## GT600

JIS (KEYWAY)

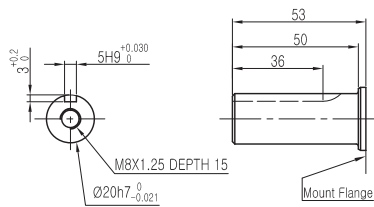

JIS (THREAD)

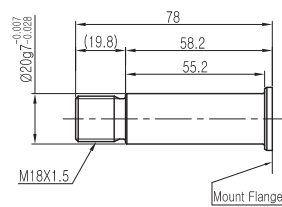

JIS (TAPER)

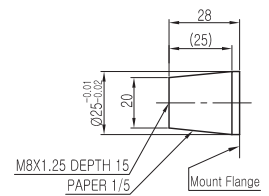

## GT1000/1300

JIS (KEYWAY)

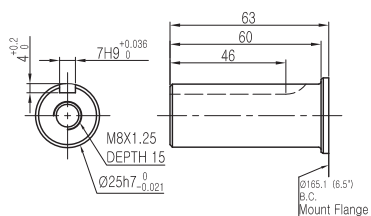

JIS (THREAD)

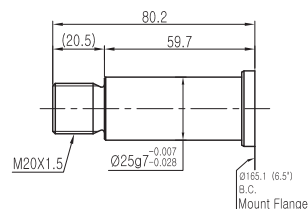

JIS (TAPER)

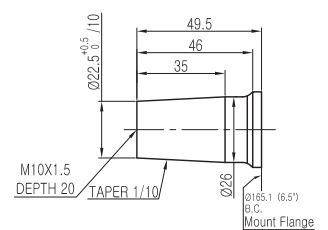



# Output shaft (PTO) specification

SAE (KEYWAY)

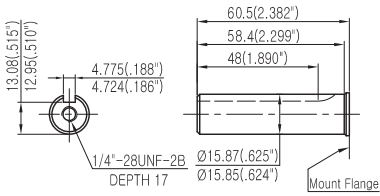

SAE (THREAD)

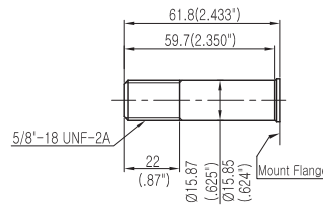

SAE (TAPER)

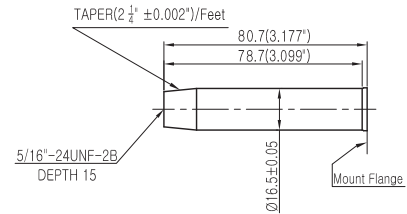

SAE (KEYWAY)

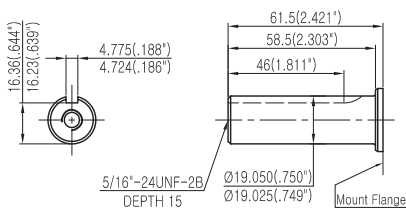

SAE (THREAD)

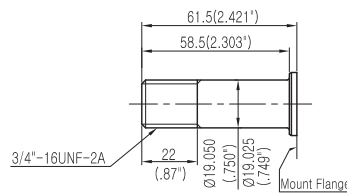

SAE (TAPER)

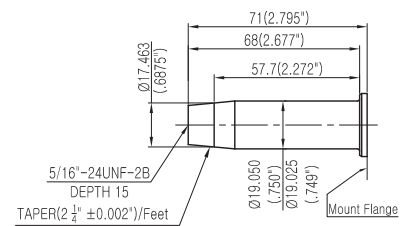

SAE (KEYWAY)

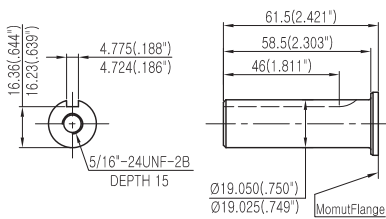

SAE (THREAD)

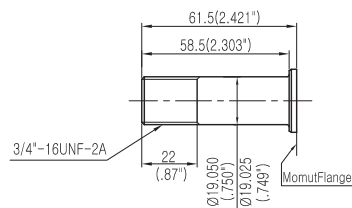

SAE (TAPER)

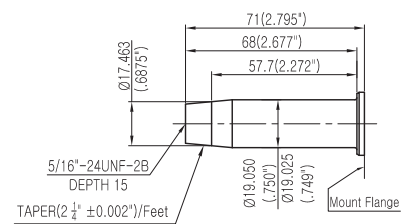

SAE (KEYWAY)

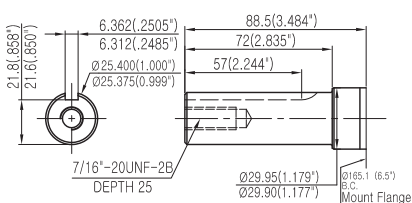

SAE (THREAD)

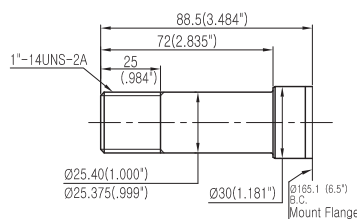

SAE (TAPER)

